

POWER PER CHANNEL:

- 6 X 150 wRMS @ 4 ohms at less than 1% THD
- 4 x 200 wRMS @ 2ohms + 2 x 250 wRMS
- 4 x 150 wRMS @ 4ohms + 1 x 500 wRMS (Ch 5+6, Bridged @ 4ohms)
- Do not bridge Ch 5+6 into 2 ohms. With two 4 ohm subwoofers, use graphic C2.

INPUTS SWITCH

- 2 = Use input 1+2 and route them to channels 3+4 and 5+6
- 4 = Use input 1+2 and 3+4
1+2 and 3+4 are attenuated by -6dB and routed to 5+6.
This allows constant bass loudness when you fade between 1+2 and 3+4.
- 6 = Use all six inputs.

CHANNELS 1 & 2 CROSSOVER CONFIGURATION

- Flat: Full Range Signal. No crossover activated.
- HP: Activates the High Pass Filter for a midbass or tweeter.
- Copy 3 & 4: Copies the signals and filters from channels 3 & 4 to channels 1 & 2. Use this mode when you need a band pass filter on all four channels. Recommended when bridging channels 1, 2, 3, 4.

CHANNELS 3 & 4 CROSSOVER CONFIGURATION

- Flat: Full Range Signal. No crossover activated.
- HP: Activates the High Pass filter.
- LP/BP: Activates the selection of either a Low Pass filter for woofer or a Band Pass filter for midrange.

CHANNELS 5 & 6 CROSSOVER CONFIGURATION

- Flat: Full Range Signal. No crossover activated.
- HP: Activates the High Pass filter.
- LP/BP: Activates the selection of either a Low Pass filter for woofer or a Band Pass filter for midrange.
- Sub Mode: Inputs 5+6 are mixed to mono for bridge mono operation. Crossover slopes become 24dB. The subwoofer remote volume control is activated. There is a clip distortion light on the remote volume control. If you see this light is on, reduce volume until the light goes out so that you do not damage your speaker.

AUTOMATIC POWER TURN ON/OFF

1. The best way to automatically turn the amplifier power on and off is to use the REM wire from your source radio connected to the REM amplifier terminal.
2. If your original equipment stereo or source radio has a BTL amplifier then the RCA inputs have an auto turn on sensing circuit. When you connect the high level BTL speaker wires to the RCA input the REM wire is not necessary.

RCA INPUT, BOTH LOW LEVEL AND HIGH LEVEL.

- The amplifier **LEVEL** control has sufficient adjustment range for both low level and high level input into the RCA jacks. A factory source radio that does not have RCA output, using the wires that are connected to the speakers, can be directly connected to the RCA jacks when the amplifier **LEVEL** control is adjusted to 8V.

SETTING LEVEL

- Set the amplifier **LEVEL** control to minimum before you turn on the amplifier for the first time.
- For lowest distortion and lowest noise the amplifier **LEVEL** should be set at the lowest setting that yields sufficient loudness without distortion. For lowest noise your source radio volume control should be near maximum that does not cause distortion.
- To find the best amplifier **LEVEL** setting:
With the amplifier **LEVEL** at minimum, slowly increase the source radio volume to around 3/4 without distortion. Then, slowly turn up the amplifier **LEVEL** control to the maximum desired loudness. Listen very carefully and turn down the amplifier **LEVEL** control if you hear any distortion.

SETTING SUBWOOFER HIGH PASS SUBSONIC FILTER

- A subwoofer should have a high pass filter often called a subsonic filter. The purpose of a subsonic filter is to limit very low frequencies that your subwoofer can not play loud enough without damage. Removing subsonic frequencies can allow your subwoofer to play louder.
- For a sealed box, the high pass is typically set between 10Hz and 30Hz to increase power handling capacity.
- For a vented box, the high pass filter must be set 5Hz lower than the port tune frequency to prevent woofer damage.

FPD 900.6 CONFIGURATION EXAMPLES

6 CHANNEL STEREO NON-BRIDGED

- **(SEE GRAPHIC C1)**
- If you have two input wires from the source deck plug them into inputs 1+2.
Set INPUT switch to 2.
- If you have four input wires from the source deck plug them into inputs 1+2 and 3+4.
Set INPUT switch to 4.
- If you have five input wires from the source deck plug them into inputs 1+2 and 3+4. The subwoofer plugs into channel 5. Set channel 5+6 MODE switch to SUB.
Set INPUT switch to 6.
- If you have six input wires from the source deck plug them into inputs 1+2, 3+4, 5+6.

Set INPUT switch to 6.

- If you are NOT using a subwoofer set all switches to flat. If you hear distortion in your woofers set all switch to HP and adjust all HP frequency until the distortion goes away. This will probably be around 50 Hz to 70 Hz.

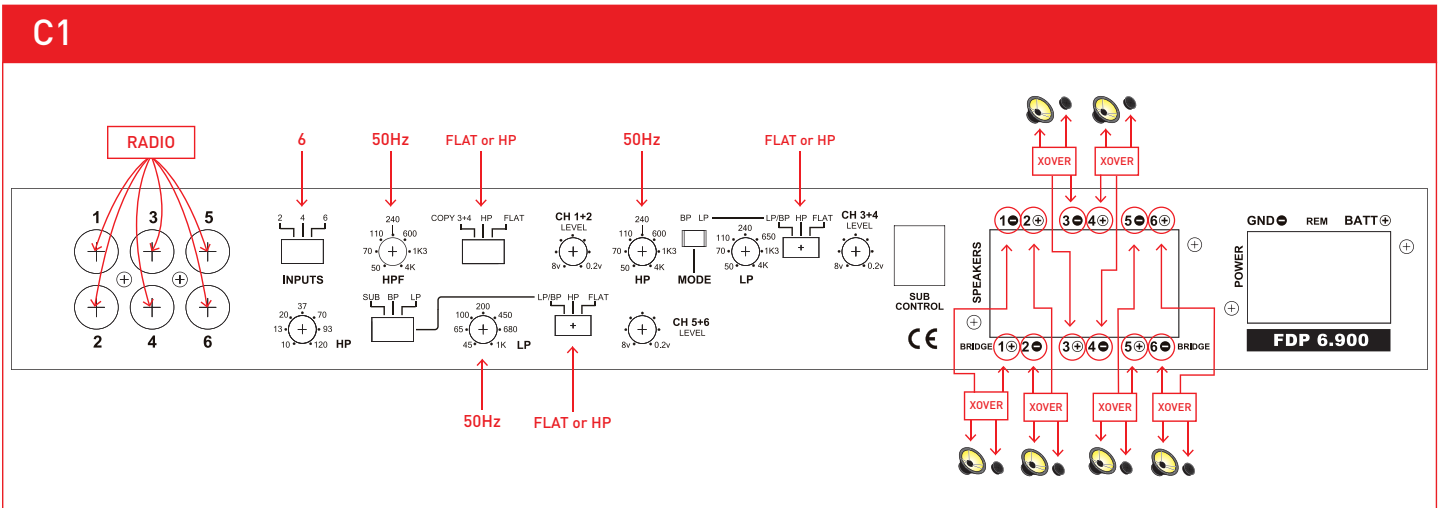

<GRAPHIC of Source Radio to input channel 1+2, 3+4, 5+6 of amplifier. Woofer/Tweeter/Xover on channels 1+2, 3+4, 5+6>

- If you are using two subwoofers: **(SEE GRAPHIC C2)**
Put your woofer/tweeters on channel 1+2, 3+4.
Set 1+2, 3+4 switch to HP.
Adjust 1+2, 3+4 HP frequency to 50 Hz.
- Subwoofers on channel 5+6.
Set channel 5+6 switch to LP/BP.
Set channel 5+6 MODE switch to SUB.
Plug in the remote sub control.
Adjust the 5+6 LP frequency to 50 Hz.
For a sealed box adjust the 5+6 HP frequency to 10 Hz.
For a vented box adjust the 5+6 HP frequency 5 Hz lower than the port tune frequency.

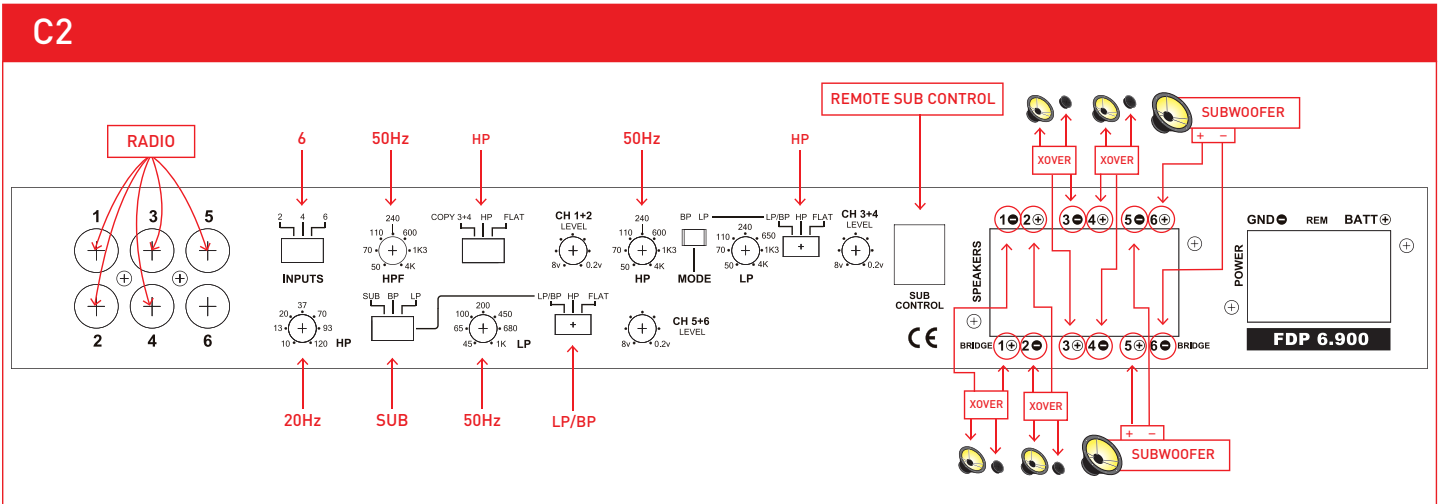

C2 <GRAPHIC of Source Radio to input channel 1+2, 3+4, 5 of amplifier. Woofer/Tweeter/Xover on channels 1+2, 3+4, one subwoofer wired to channel 5 one subwoofer wired to channel 6>

5 CHANNEL WITH BRIDGED SUBWOOFER

- **(SEE GRAPHIC C3)**
- If you have two input wires from the source deck plug them into inputs 1+2.
Set INPUT switch to 2.
- If you have four input wires from the source deck plug them into inputs 1+2 and 3+4.
Set INPUT switch to 4.
- If you have five input wires from the source deck plug them into inputs 1+2 and 3+4. The subwoofer plugs into channel 5.
Set channel 5+6 MODE switch to SUB.
Set INPUT switch to 6.
- If you have six input wires from the source deck plug them into inputs 1+2, 3+4, 5+6.
Set INPUT switch to 6.
- Put your woofer/tweeters on channel 1+2, 3+4.
Set 1+2, 3+4 switch to HP.
Adjust 1+2, 3+4 HP frequency to 50 Hz.
- One subwoofer bridged mono is wired to channel 5+ and channel 6-.
Set channel 5+6 switch to LP/BP.
Set channel 5+6 MODE switch to SUB.
Plug in the remote sub control.
Adjust the 5+6 LP frequency to 50 Hz.
For a sealed box adjust the 5+6 HP frequency to 10 Hz.
For a vented box adjust the 5+6 HP frequency 5 Hz lower than the port tune frequency.

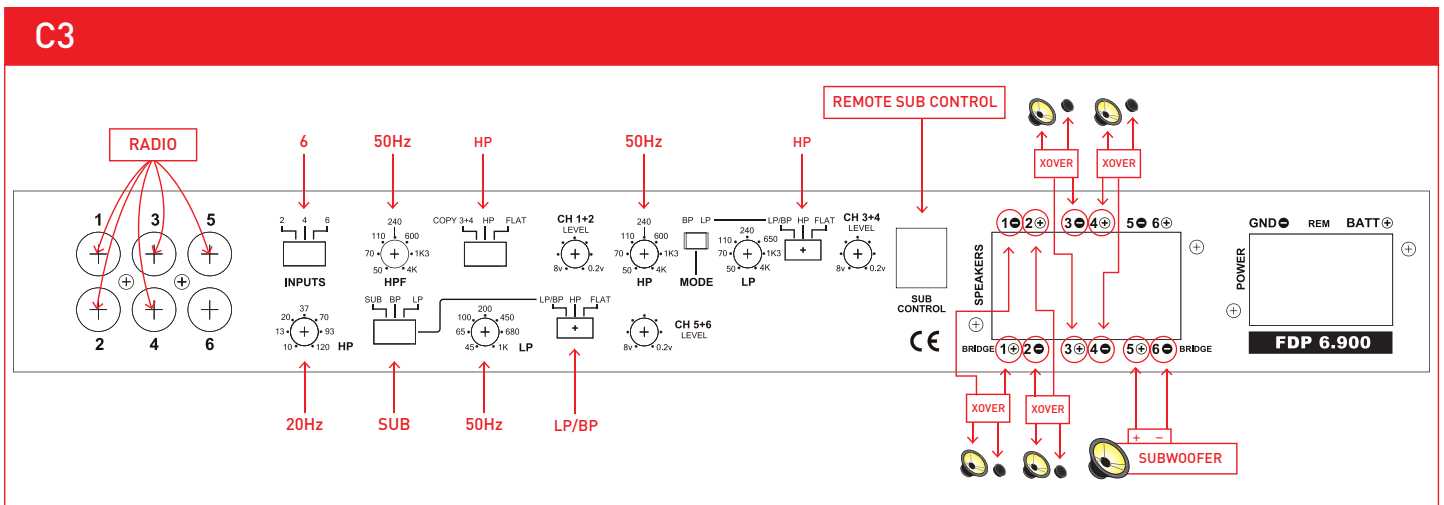

C3 ←GRAPHIC of Source Radio to input channel 1+2, 3+4, 5 of amplifier. Woofer/Tweeter/Xover on channels 1+2, 3+4, one subwoofer wired to channel 5+ and channel 6-→

TRIAMP A SUBWOOFER, WOOFER, AND TWEETER:

- **(SEE GRAPHIC C4)**
- Connect the source deck front channel wires into inputs 1+2.
Set INPUTS switch to 1+2.

- Connect your tweeters to channels 1+2.
Set 1+2 switch to HP.
Adjust 1+2 HP frequency to the tweeter manufactures recommendation. 3500 Hz is a good starting point.
- Connect your woofers to channels 3+4.
Set channel 3+4 switch to LP/BP.
Set channel 3+4 switch to BP.
Adjust the 3+4 LP frequency to the manufactures recommendation. 3500 Hz is a good starting point.
Adjust 3+4 HP frequency to 50 Hz.
- If you have two subwoofers connect one to channel 5 and one to channel 6.
- If you have one subwoofer connect it to channel 5+ and channel 6-.
- Set channel 5+6 switch to LP/BP.
Set channel 5+6 MODE switch to SUB.
Plug in the remote sub control.
Adjust the 5+6 LP frequency to 50 Hz.
For a sealed box adjust the 5+6 HP frequency to 10 Hz.
For a vented box adjust the 5+6 HP frequency 5 Hz lower than the port tune frequency.

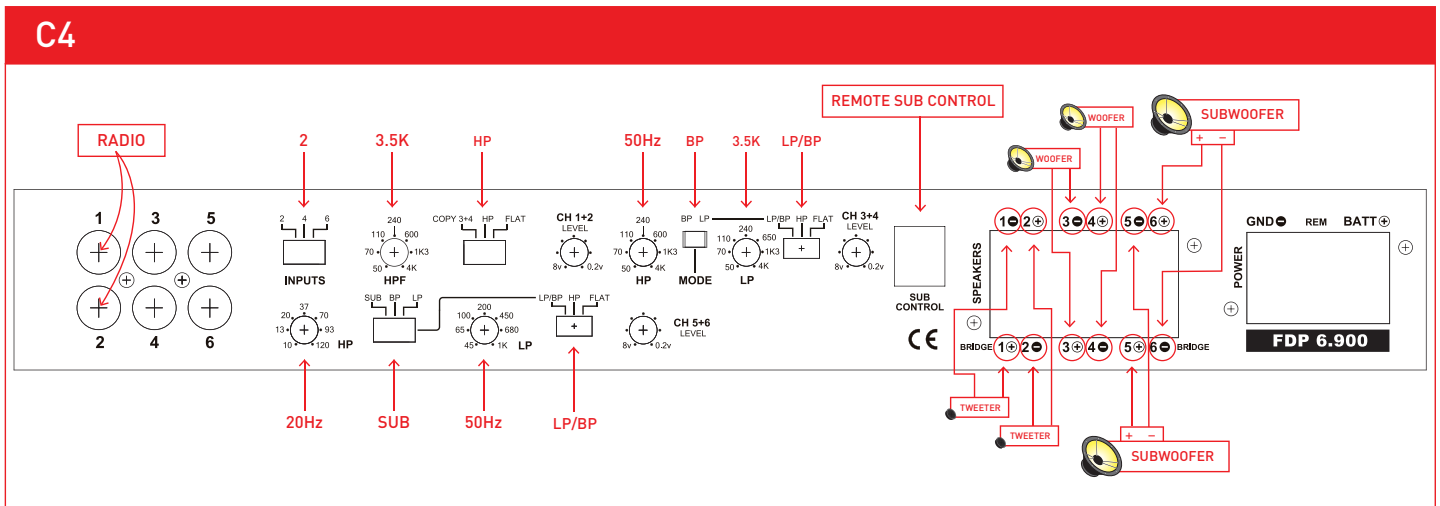

C4 ←GRAPHIC of Source Radio to input channel 1+2 of amplifier. Tweeter on channels 1+2. Woofer on channels 3+4. one subwoofer wired to channel 5, one subwoofer wired to channel 6→

POWER FUSES & BALANCED/UNBALANCED SWITCHES:

6.900 POWER FUSES

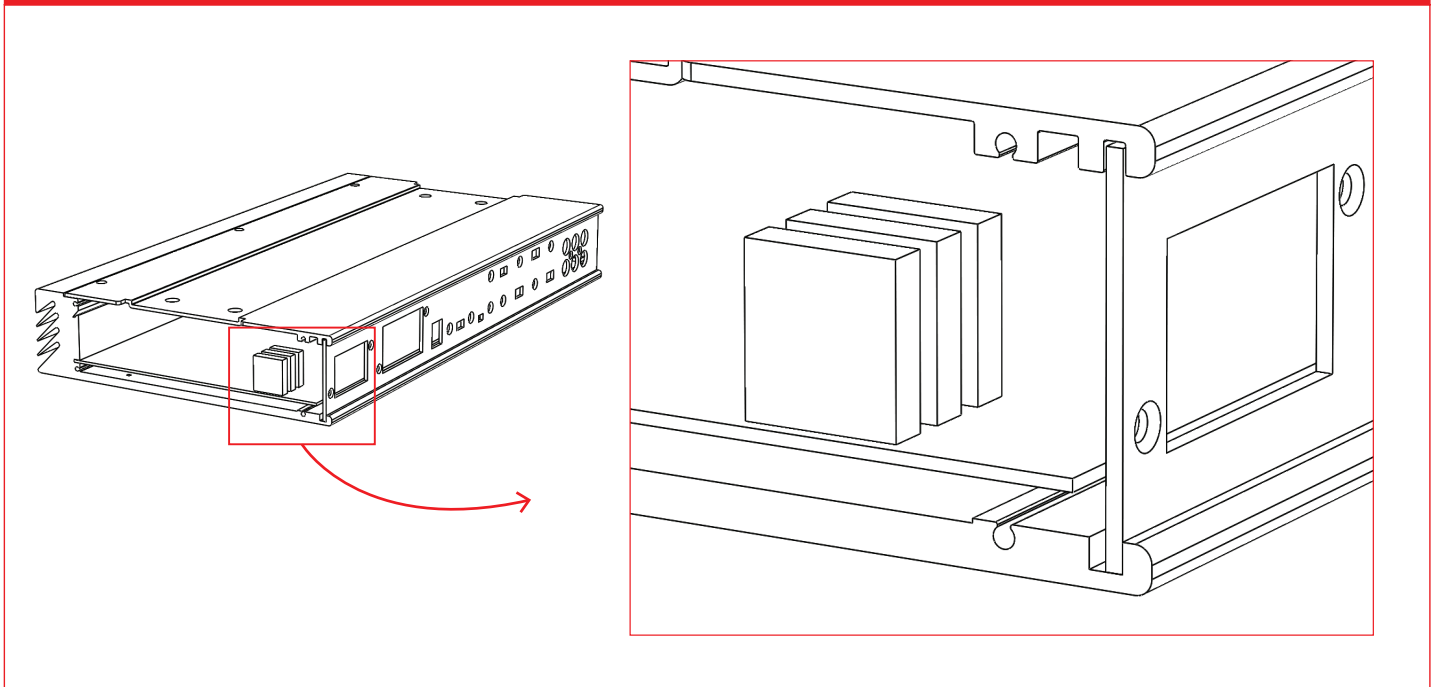

→ **TO USE:** Remove the end panel by the power terminals
3 x 25 amp ATC fuse

6.900 BALANCED/UNBALANCED SWITCHES

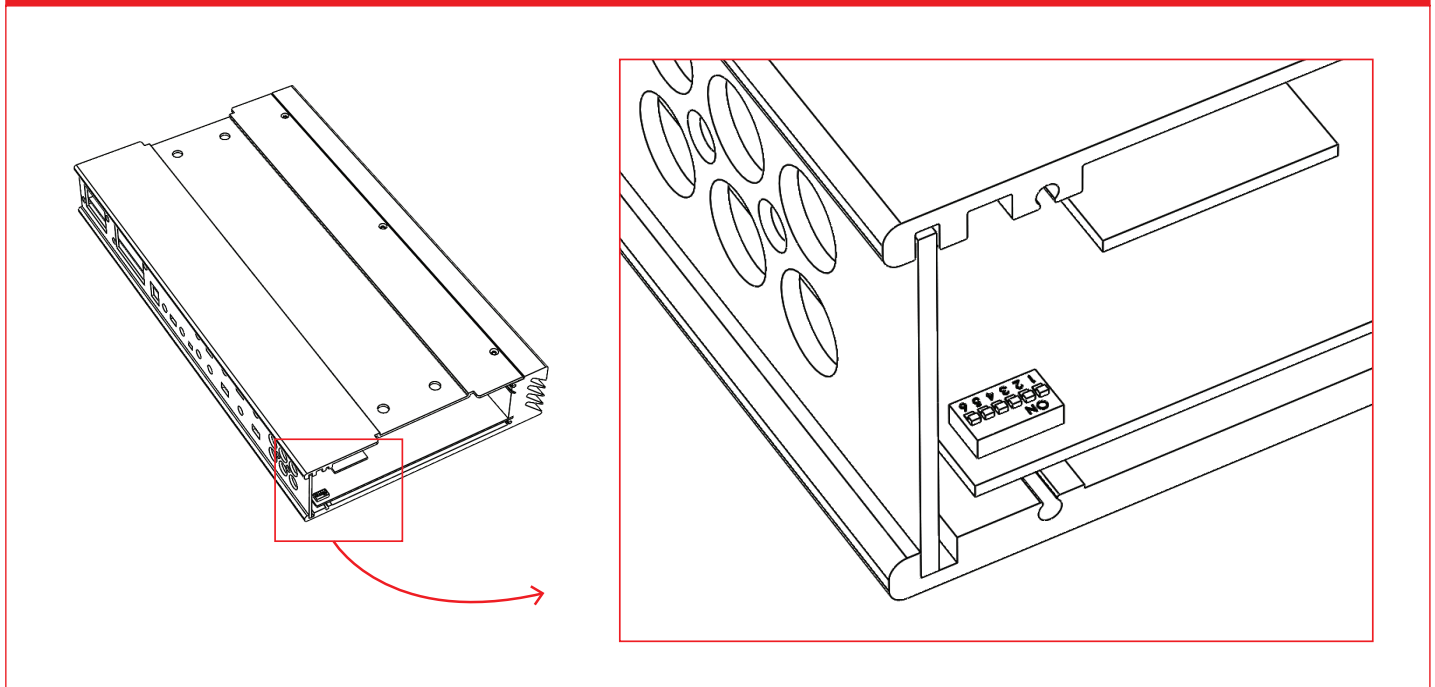

→ **TO USE:** Remove the end panel by the RCA jacks.
The standard switch position is input ground "ON".
Flip the switch "OFF" changes the input to "balanced input floating ground".
To flip the switch, use a small pick or jewelers screw driver.

TROUBLESHOOTING:

→ FOCAL SIGN DOES NOT LIGHT

1. Measure the voltage at the amplifier power terminal.
It should be between 12 and 15 volts.
2. Measure the voltage at the amplifier REM terminal.
It should be between 12 and 15 volts.
3. If you are using BTL high level for automatic turn on, try connecting a REM wire.
4. Check your power and ground connections to be correct polarity + and - and they are tight.
5. Check battery connections.
6. Check the fuse in the REM wire.
7. Check fuse at battery.
8. Check fuse inside amplifier.
The fuse is inside the right end cap beside the power terminals.
The recommended ATC fuse size is two 25 amp.

→ FOCAL SIGN IS FLASHING

1. Is the amp very hot?
Wait a few minutes for it to cool down.
You need to get more fresh cool air to the amplifier.
Do not cover the amplifier or mount it flush into a hole.
2. If the amp is cold and the Focal sign is flashing, there is an internal fault. The amplifier must then be returned for service.

→ NO SOUND

1. Is the Focal sign light off or flashing?
2. Is the source radio on and is there a sound signal coming from the source radio?
3. Use an ohm meter and measure the speaker wires for short circuit.
4. Check connections for small "wire whisker" that may be shorting between amplifier terminals or speaker terminals.
5. Use an ohm meter and measure the speaker for short circuit.
6. Double check your connections to the source radio.
7. Are you using the correct source radio wires and are they plugged into the correct amplifier RCA?
8. Double check your connections to the speakers and speaker crossovers.
9. Check that all amplifier switches are in the correct positions for your speaker set up.

→ AMPLIFIER BLOWS FUSE WHEN YOU TURN IT ON.

1. Power and ground may be reversed.
Check + and - polarity at amplifier and at battery.

→ SUBWOOFER REMOTE VOLUME CONTROL DOES NOT FUNCTION.

1. Check that Remote Volume Control wire is plugged into the amplifier securely.
2. The Remote Volume Control will not function if the amplifier switch is "DIRECT". The switch must be in "MASTER".

→ SUBWOOFER REMOTE VOLUME CONTROL LED LIGHT.

1. While playing music the LED light should be Green.
Occasional red LED light flash indicates that the amplifier has reached maximum loudness.
2. If the red LED light flashes with the beat of the music,
TURN DOWN THE VOLUME before you damage your speaker.
3. If the red LED light is on continuous,
TURN DOWN THE VOLUME before you damage your speaker.

WARRANTY INFORMATION:

Focal America / Orca Design & Manufacturing supports their products and guarantees them to be free of manufacturing defects for a period of **1 year (non-transferrable) from the date of purchase, if purchased from and authorized retailer**. This time period is extended to **3 years (non-transferrable) from the date of purchase, if the amplifier is purchased from and installed by an authorized retailer**, and **no alterations** are made to the installation or setup of the amplifier outside of the authorized retailer.

This manufacturing **warranty does not extend to situations involving physical or installation damage, misuse, abuse, or modification**. If an amplifier malfunctions, please return it to the authorized retailer from which the amplifier was purchased to have the amplifier and/or installation inspected and to have the warranty period verified from date of purchase.

The authorized dealer will then work with Focal America / Orca Design & Manufacturing to obtain service, if necessary. If found to be a defect due to manufacturing, the item will be repaired or replaced with a refurbished amplifier. The amplifier will be returned to the authorized retailer when repairs are complete, so that the dealer can return the amplifier to you, or reinstall the amplifier to maintain the above mentioned warranty timeline.

TECHNICAL SPECIFICATIONS:

Six X 150 watts at less than 1% THD into 4 ohms Four X 200 watts + two X 275 watts at less than 1% THD into 2 ohms Bridged, two X 400 watts + one X 500 watts at less than 1% THD into 4 ohms Frequency Response 5 Hz to 25 kHz. S/N ratio 90 dB RCA input can use a BTL source or common ground source. RCA switch select balanced floating ground or grounded to minimize noise. Input sensitivity 200mV to 10 volts Slew Rate 13 V / uS Each input has a peak limiter to prevent clipping and speaker damage.	Each channel has variable high pass crossover: 50 Hz to 4000 Hz, 12 dB Linkwitz-Riley Each channel has variable low pass crossover: 50 Hz to 4000 Hz, 12 dB Linkwitz-Riley Each channel has variable band pass crossover: 50 Hz to 4000 Hz, 12 dB Linkwitz-Riley Channels 5, 6 in bridged subwoofer mode , 24 dB Linkwitz-Riley Subwoofer remote volume control includes a clipping indicator light. Recommended DC voltage operating range 11.5 to 14.4 volts. Minimum DC voltage operating range 8 to 16 volts. Length 7.71 inches Width 14.33 inches Height 1.97 inches Weight 8 pounds
---	---