

IC BMW 100L

Product Data Sheet

IC BMW 100L is designed for drivers who want to replace their original audio system with a quality sound solution adapted to their vehicle. This kit is equipped with the neodymium engine and the Aluminium/Magnesium inverted dome tweeter, exclusive Focal technologies for high power handling and perfectly rendered trebles.

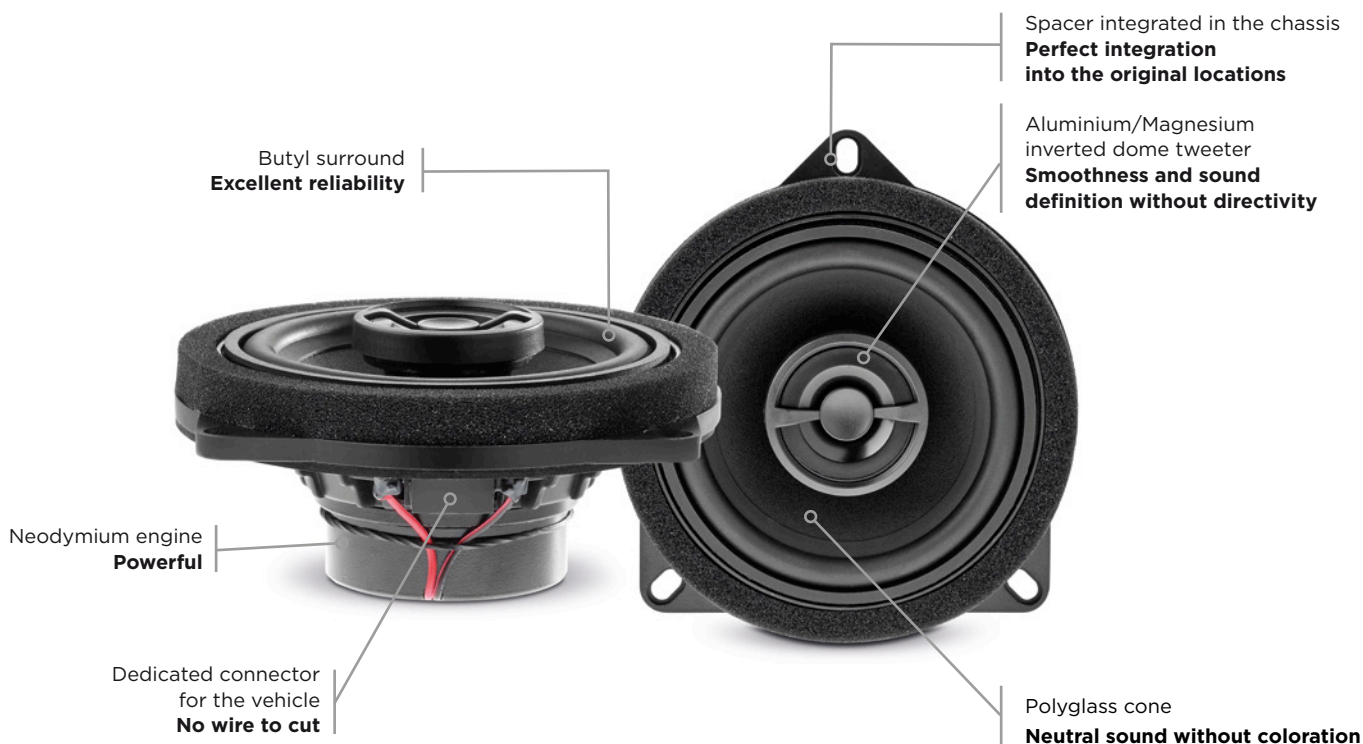

Key Points

- Quick installation
- No wire to cut, no modification
- 100% compatible with your vehicle
- Sound quality superior compared to the original one
- Mounting accessories included

Check your vehicle compatibility at www.focal-inside.com



[BMW : Série 1, Série 3, Série 5, X1, X3...
Mini : F56, F57, F60...]

Type	2-way coaxial kit
Woofer	5" (100mm)
Tweeter	Inverted dome
Magnet	Neodymium
Cone	Black Polyglass
Surround	Butyl
Impedance	4Ω
Max. power	80W
Nom. power	40W RMS
Sensitivity (2.83V/1m)	89.5dB
Frequency response	80Hz-23kHz
Crossover	Separated

FOCAL® INSIDE

Focal® is a trademark of Focal-JMLab® - www.focal.com - SCAA191003/1

FOCAL®
LISTEN BEYOND